

Industrial HPLC



EPCC / PRODUCTS / APPLICATION / SOFTWARE / ACCESSORIES / CONSUMABLES / SERVICES

Analytical Technologies Limited

An ISO 9001 Certified Company

www.analyticalgroup.net

▶▶ **Section I: Introduction**

▶▶ **Section II: Equipment**

1. 15 LPM HPLC Skid
2. Control System and Software Description
3. HPLC Dynamic Axial Compression Columns

Section III: Equipment Services

1. IQ/OQ Validation Services
2. Factory Acceptance Test
3. Equipment Start-up, Training, and Validation
4. Telephone and Email Technical Support
5. On-Site Technical Support
6. Extended Warranty Coverage

Section IV: Equipment Completion Time

Section V: Dedicated Project Management

Section VI: Analytical Terms and Conditions

Section VII: QUOTATION SHEET

▶▶ **Section I: Introduction**

Analytical[®] designs, manufactures, validates, operates and supports the most robust, technologically advanced and cost effective cGMP liquid chromatography equipment available. Our equipment design is based on our expertise in the purification of both synthetic and natural products across a broad range of biopharm, pharmaceutical and fine chemical products ranging from small organic molecules such as synthetic peptides to large proteins. With its built in CIP capability, our equipment is well suited for dedicated, as well as, multi-product cGMP manufacturing environments.

►► Some key advantages provided by Analytical

- Our equipment provides the lowest purification cost for high value added synthetic products achieving the highest purity, loading and recovery of product in cGMP environments.
- Analytical LC systems are truly multi-product capable with a low dead volume, sanitary design which permits rapid, automated CIP (cleaning in place).
- Analytical standard platform is in compliance with codes such as FDA, ASME, and 21 CFR Part 11. Asian and European equivalents provided upon request.
- Analytical columns have the world's most effective flow distributor design, resulting in optimum plate counts (N), lowest back pressure and longest bed life. This improves resolution from related impurities and reduces production costs with higher recovery, purity and throughput.
- Woven mesh 316L stainless steel frits can be replaced easily.
- Analytical LC columns are flexible and easy to use. They are suitable for all types of LC as well as solid phase synthesis vessels and capture columns.

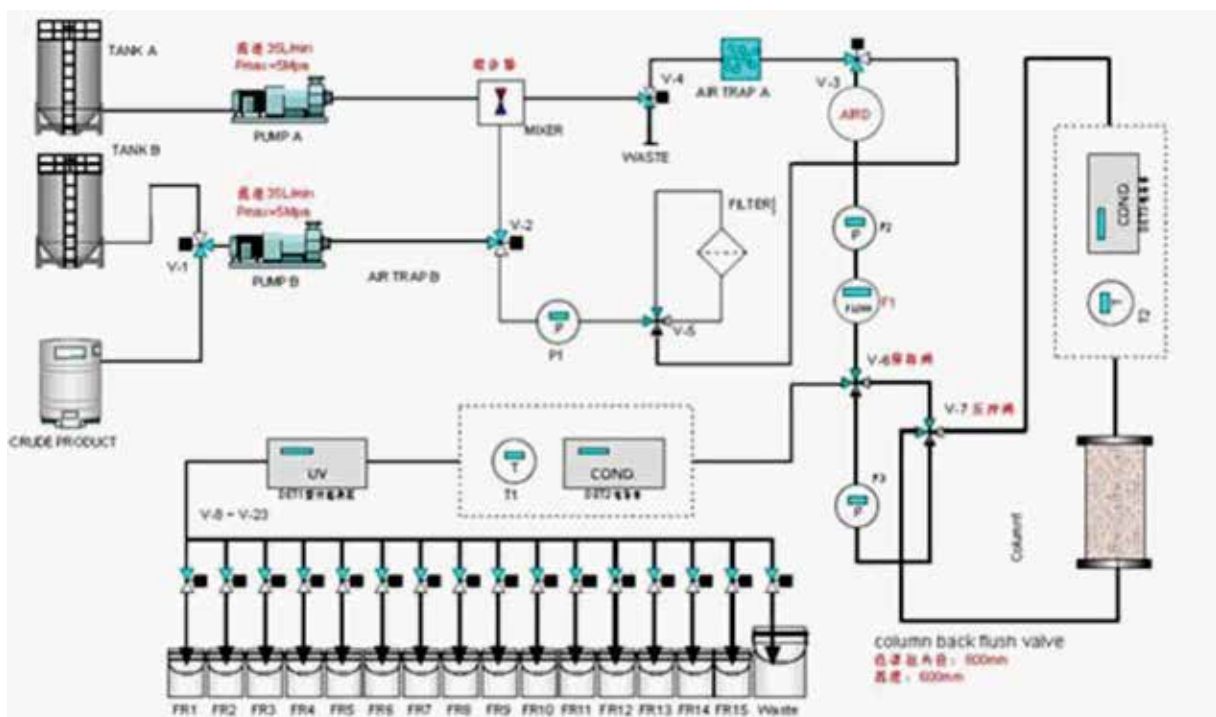

▶▶ Section II: Equipment

1. Analytical HPLC Purification Skid System

15LPM-HPLC-200bar 15L/min 200bar

This is a design cGMP HPLC skid system with industrial construction & 316LSS frame appropriate for multi-product cGMP work and optimized for different kinds of products purifications.

- 316L Stainless Steel frame is provided with all welds ground and polished.
- Sanitary system tubing, fittings and valves are traceable 316L stainless steel and electropolished on the interior with boroscopically inspected and documented orbital welding.
- 316L Stainless Steel flowpath. All custom piping fabrications are individually PINstamped for full traceability. Interior surface finish is $\leq 20 \mu\text{mR}_a$.
- FDA approved materials of construction are provided for all product contact seals
- 6 sanitary buffer/solvent inlet ports are arranged with 316L stainless steel, low dead volume cluster valve assemblies.
- Precision process control valves provide buffer/solvent isocratic and gradient blending to within +/- 1% accuracy;
- 1 sample inlet port
- 1 in-line end-of-stream air sensor before the main pump
- Main Pump: 15L/min 200 bar triple head Lewa double diaphragm pump includes diaphragm condition monitors.
- Pre-column pressure sensor and transmitter
- Column bypass, forward flush and back flush valves are provided in a low dead volume sub-assembly
- Mass Flow Meter (Endress + Hauser) provides feedback to main pump to keep flow rate extremely accurate while submitting real time flow rate documentation into batch reports. Flow rate is measured in mass units eliminating effects of varying mobile phase component viscosity. This feature is also used to accurately control & record sample loading.
- Post column variable wavelength Knauer UV detector permits the use of varying wavelengths automatically within a single run. Lamp failure alarm is also included.
- Low dead volume fiber optic UV flow cell has no cell windows to become dirty or leak and includes adjustable path length capability.
- Conductivity and PH online detection, monitoring and feedback.
- Fraction collection ports with 8 outlets are arranged with sanitary 316L stainless steel, low dead volume cluster valve assemblies which reduce hold up volume between fraction ports so impurity carryover or product loss is minimized.
- All critical instruments are factory calibrated.
- Utilities: 3 phase, 440/480V power (or other as required), and 6 bar instrument grade air.

- Class 1, Division 2 hazardous area rating for control panel includes all electrical starters, relays, drives, power supplies and wiring. Control box is mounted to the skid, and wiring from the control box to the skid field instrumentation is included.

The control box is purged with a Type Z purge system. An on/off disconnect switch, Estop and pause buttons, and pressure switch for instrument grade air is included.

- All Analytical systems are built according to our SOP's to ensure that the highest state of quality control is incorporated into each system.
- Warranty: for 1 year as detailed in Analytical P.O.A. which can be extended up to 3 years.

▶▶ **2. Control System & Software Description :**

- The operating system for our 21 CFR Part 11 capable software is Microsoft Windows XP. Data compilation, storage, & batch report generation capability Software Description:

- Easily migrate from screen to screen
- Methods are quickly created and edited. Linear and step gradients, isocratic blends, priming, crude feed loading, and CIP steps are all available, as well as customized steps upon request.
- Methods can be exported as XML files for transferring
- Program steps based on time, volume or column volume
- User can view her/his entire method on one screen
- Fractionation can be programmed based on time, volume, UV signal, or combinations
- Easy-to-follow P&ID style process control screen with status animation
- Automatic mode, manual mode, and manual override capabilities.
- Ability to view and track totalized volumes eluting through each outlet port
- Process and device alarm displays and alarm management
- Alarm hierarchy can be customized to meet user requirements
- Data trend screens allow the user to view all analog signals simultaneously
- Trending provides one second real-time data resolution on screen (rather than the 30 second data collection with simulated real time appearance used by all other process control packages)
- Ability to manually or automatically set the x-axis and y-axis scale for the trend views
- User-friendly zooming in and out on the trend views with mouse
- Ability to view up to four analog signals simultaneously on the trend views
- Overlay previous golden batches on Trend screen for comparison during production runs with runtime (start at time zero) x-axis and 24 hour process time clock; all data (pressure, flow, UV, Conductivity, PH) can be overlaid.
- New Analytical data analysis package for peak integration, HETP or N (plate count calculations) and Asymmetry.

- Up to 10-user access levels can be created for system security. 21 CFR Part 11 (highest level) capable process control software including electronic signature and audit. Note that this is full Part 11 capability, not the generic capability claimed by other suppliers. It provides all of the elements of a 21 CFR-Part 11 capable SW package which would include, but not be limited to: passwords, complete and secure electronic audit trails, locked-down databases for both analog signal data and method data, system and application level security, as well as electronic signatures, all subject to on-site conditions.

▶▶ **Analytical[®] 21 CFR Part 11 Software Detailed Description**

Analytical[®] 21 CFR Part 11 Package, includes the following elements: passwords, complete and secure electronic audit trails, locked-down databases for both analog trend data and method data, system and application level security, as well as electronic signatures, to provide full 21 CFR Part 11 performance. Details of these elements, as well as other functional elements of the software package, are listed below. Operation under protocols that are compliant with 21 CFR Part 11 requirements is the responsibility of the end user.

▶▶ **A. Title 21 Code of Federal Regulations Part 11 Features**

The following criteria are addressed with our 21 CFR Part 11 capable software package, with references to the Code subparts:

▶▶ **Title 21 - Food and Drugs Chapter I - Food and Drug Administration, Department of Health and Human Services**

▶▶ **Subpart B - Electronic Records Controls for closed systems.**

Persons who use closed systems to create, modify, maintain, or transmit electronic records shall employ procedures and controls designed to ensure the authenticity, integrity, and, when appropriate, the confidentiality of electronic records; such procedures and controls shall include the following:

b) The system will generate a secure, computer-generated, and time-stamped audit trail so as to independently record the time and date of operator entries that create, modify or delete electronic records.

c) Protection of records to enable their accurate and ready retrieval throughout the records retention period.

d) Limiting system access to authorized individuals.

e) Use of secure, computer-generated and time-stamped audit trail so as to independently record the time and date of operator entries that create, modify or delete electronic records. Record changes shall not obscure previously recorded information.

g) Use of authority checks will be used so that only authorized individuals can use the system, electronically sign a record, access the computer system input or output device, alter a record, or perform the operation at hand.

▶▶ **Subpart C – Electronic Signatures**

General requirements.

a) Each electronic signature shall be unique to one individual and shall not be reused by, or reassigned to, anyone else. Electronic signature components and controls.

a) Electronic signatures... shall:

1) Employ at least two distinct identification components such as an identification code and password.

i) When an individual executes a series of signings during a single, continuous period of controlled system access, the first signing shall be executed using all electronic signature components; subsequent signings shall be executed using at least one electronic signature component that is only executable by, and designed to be used only by, the individual.

ii) When an individual executes one or more signings not performed during a single, continuous period of controlled system access, each signing shall be executed using all of the electronic signature components. Control for identification codes/passwords. Persons who use electronic signatures based upon use of identification codes in combination with passwords shall employ controls to ensure their security and integrity. Such controls shall include:

(a) Maintaining the uniqueness of each combined identification code and password, such that no two individuals have the same combination of identification code and password.

(b) Ensuring that identification code and password issuances are periodically revised (e.g., to cover such events as password aging).

▶▶ **B. Other features of the package that contribute to 21 CFR Part 11 capability**

- User IDs can be of varying is minimum character length, determined by the Administrator
- Passwords can be of varying is minimum character length, determined by the Administrator
- Users will periodically change their password, determined by the Administrator (e.g.60 days)
- Access violations will be recorded so that the system administrator may review
- User access is suspended after three successive failed attempts
- Inactivity periods will i\$time outi` the user; inactivity period to be determined by the Administrator
- Up to 10 user access levels can be created for system security.
- Databases shall be locked down for both raw data and method parameter data

▶▶ 3. HPLC Dynamic Axial Compression Columns with Jacket

DAC-600x650-2000psi ID600mm x 650mm length

Easy to pack, un-pack, operate and maintain, Analytical[®] 316L stainless steel HPLC columns also provide highest performance in plate count, flow versus pressure curves and resistance to void and channel formation. The price includes the dynamic axial compression LC column, wheeled leg supports for the column, hydraulic station with all interconnecting hoses, valves and fittings, tools, and user's manual with IQ/OQ documentation. Analytical 316L SS adaptive dynamic axial compression HPLC columns feature:

- 316L stainless steel construction for the column, supports, and hydraulic station.
- Interior surface finish is less than 15 mm.
- Slurry inlet port allows packing and unpacking without removing the column flanges.
- Low dead volume, low shear 316L SS effective flow distributor plates provide highest column performance (HETP or N) and lower pressure drop.
- Analytical[®] removable 316L SS woven mesh multi-layered frits are least susceptible to clogging, and can be back- flushed, ultrasonically cleaned or replaced in minutes.
- Analytical[®] self-energized spring piston seals set the industry standard for consistent sealing and do not use non- approved dyes or hardening agents
- Internal leak detection system provides quality assurance that the seals are properly positioned during replacement and throughout operation.
- The column permits fully variable bed length.
- Time-to-pack and time-to-unpack is minutes and can be performed in a controlled cGMP manner using the provided documentation.
- The end of the piston head has a virgin Teflon scraper seal that cleans the column tube during un-packing for complete CIP and eliminates media getting past the piston.
- Analytical[®] auto-slurry system for the DAC column packing
- The column is designed and tested according to the latest ASME pressure vessel guidelines.
- Warranty: All equipment is warranted for 1 year against defects as detailed in Analytical terms and conditions of sale below.

▶▶ Section III: Equipment Services

1. Validation Services

A. IQ/OQ Validation Documentation

This industry leading comprehensive system IQ/OQ package documents the detailed quality assurance procedures performed by Analytical during the fabrication and in-depth testing performed on your automated HPLC system. It includes, but is not limited to, the following:

- All documentation is provided in English (other languages at additional cost).
- Full system component list with manufacturer, connections sizes, component model's and serial's.
- All component certifications, including certificates of compliance and calibration certificates, where appropriate.
- All component manuals and cut sheets.
- System Piping & Instrumentation diagram for Design Qualification
- General Arrangement drawings for Design Qualification
- Material heat sheets and traceability certs
- Weld Logs for all product contact pipework
- Complete electrical schematics and electrical component list.
- Control panel layout
- All electrical component manuals and cut sheets.
- User's manual

2. Factory Acceptance Test

Clients can attend F.A.T. proceedings in order to review all IQ/OQ documentation and perform a one-day equipment check-out. One day is allotted for FAT. This does not include any customer specified testing procedures, which can be performed by mutual agreement for additional cost. Those costs will be based on time, materials, equipment, and facility charge once the customer specified procedure and tests have been finalized.

3. Equipment Start-up, Training, and Validation: On-site start-up and training

This includes on-site equipment inspection, start-up, SAT and operator training. Expect 5 days. Business travel costs including airfare, car, hotel and meals are additional. On-site Equipment Validation This includes on-site equipment IQ/OQ validation. Expect approximately 1 week. Business travel costs including airfare, car, hotel and meals are additional.

4. Technical Support by Email, Fax and Telephone

Analytical[®] is dedicated to providing the fastest and most complete technical support of any equipment manufacturer. We have a staff of trained engineers and chemists with hands on process LC experience to provide free technical support during the hours of 9:00am to 6:00pm CST MONDAY to FRIDAY within warranty period.

5. On-Site Technical Support

Analytical[®] will train client personnel to be self sufficient to service and maintain the equipment. Analytical[®] will train personnel from Biocon Company to provide on-site service at client and maintain the equipment. This will include a 3 day training program for up to 4 client representatives.

6. Extended Warranty Coverage

At the time of purchase, an extension of the provided 1-year warranty is available at a cost of 5% of the equipment purchase price per year of extended coverage to a maximum of 5 years. The coverage must be purchased at the time of equipment order.

This warranty coverage includes:

- As in the original warranty, all skid and column hardware including pumps, components, instruments and software are covered, except those parts subject to regular replacement due to normal wear and tear (e.g., gaskets, washers, seals). Note: this does not include damages caused by operator error, neglect, accident, failure to follow training directives and operation manuals or other non-defect related circumstances.
- All engineering expenses required for on-site warranty repairs as required during the extended period. All business travel, lodging and meals are not included in the extended warranty coverage and must be covered by the customer.
- Crating and handling costs must be paid by the customer. Expedited equipment shipping charges are also the responsibility of the customer.

▶▶ **Section IV: Equipment Completion Time**

This equipment will be ready for FAT approximately 16 working weeks (90 business days) from receipt of initial payment and signed PO Acknowledgement.

▶▶ **Section V: Dedicated Project Managers**

Analytical provides an Engineering Project Manager to act as a single point of contact throughout the project to ensure prompt delivery, validation, start-up and continued technical support of all equipment.

HPLC Servicing, Validation, Trainings and Preventive Maintenance :

HPLC Servicing :HPLC Servicing : We have team of service engineers who can attend to any make of HPLC promptly @the most affordable cost.

Trainings :We also take up preventive Maintenance to reduce downtime of HPLC's Trainings.

AMC's/CMC :AMC's/CMC :We offer user training both in-House and at customer sites on HPLC principles, operations, trouble-shooting.

Validations :Validations :We have protocols for carrying out periodic Validations as per GLP/GMP/USFDA norms.

Instruments :Instruments :We offer instruments/Renting Services Modules like pumps,detector etc. on Rent.



About Analytical Technologies

Analytical Technologies is synonymous for offering technologies for doing analysis and is the Fastest Growing Global Brand having presence in at least 96 countries across the global. Analytical Technologies Limited is an ISO:9001 Certified Company engaged in Designing, Manufacturing, Marketing & providing Services for the Analytical, Chromatography, Spectroscopy, Bio Technology, Bio Medical, Clinical Diagnostics, Material Science & General Laboratory Instrumentation. Analytical Technologies, India has across the Country operations with at least 4 Regional Offices, 6 Branch Offices & Service Centers. Distributors & Channel partners worldwide.

Our Products & Technologies



Regulatory compliances



Corporate Social Responsibility

Analytical Foundation is a nonprofit organization (NGO) found for the purpose of:



Analytical
Foundation

1. Research & Innovation Scientist's awards/QC Professional Award : Quality life is possible by innovation only and the innovation is possible by research only, hence ANALYTICAL FOUNDATION is committed to identify such personalities for their contributions across various field of Science and Technology and awarding them yearly. To participate for award, send us your details of research / testing / publication at Info@analyticalfoundation.org

2. Improving quality of life by offering YOGA Training courses, Work shops/Seminars etc.

3. ANALYTICAL FOUNDATION aims to DETOXIFY human minds,souls and body by means of yoga, Meditation, Ayurveda, Health Care, Awards, Media, Events, Camps etc.

Reach us @



HPLC Solutions MultipleLabs Analytical Bio-Med Analytical Distributors Analytical Foundation (Trust)

Corporate & Regd. Office:
Analytical House, # E67 & E68,
Ravi Park, Vasna Road, Baroda,
Gujarat 390 015. INDIA

T: +91 265 2253620
+91 265 2252839
+91 265 2252370
F: +91 265 2254395

E: info@hplctechnologies.com
info@multiplelabs.com
info@analyticalgroup.net
info@analyticalbiomed.com

W. www.analycalgroup.net
www.hplctechnologies.com
www.multiplelabs.com
www.ais-india.com

Sales & Support Offices:
across the country :
Distributors & Channel
partners World Wide

Note : Company reserves rights to add/delete/modify the contents / technical specifications of the catalogue without prior notice.